

MANUFACTURING PROCEDURE:

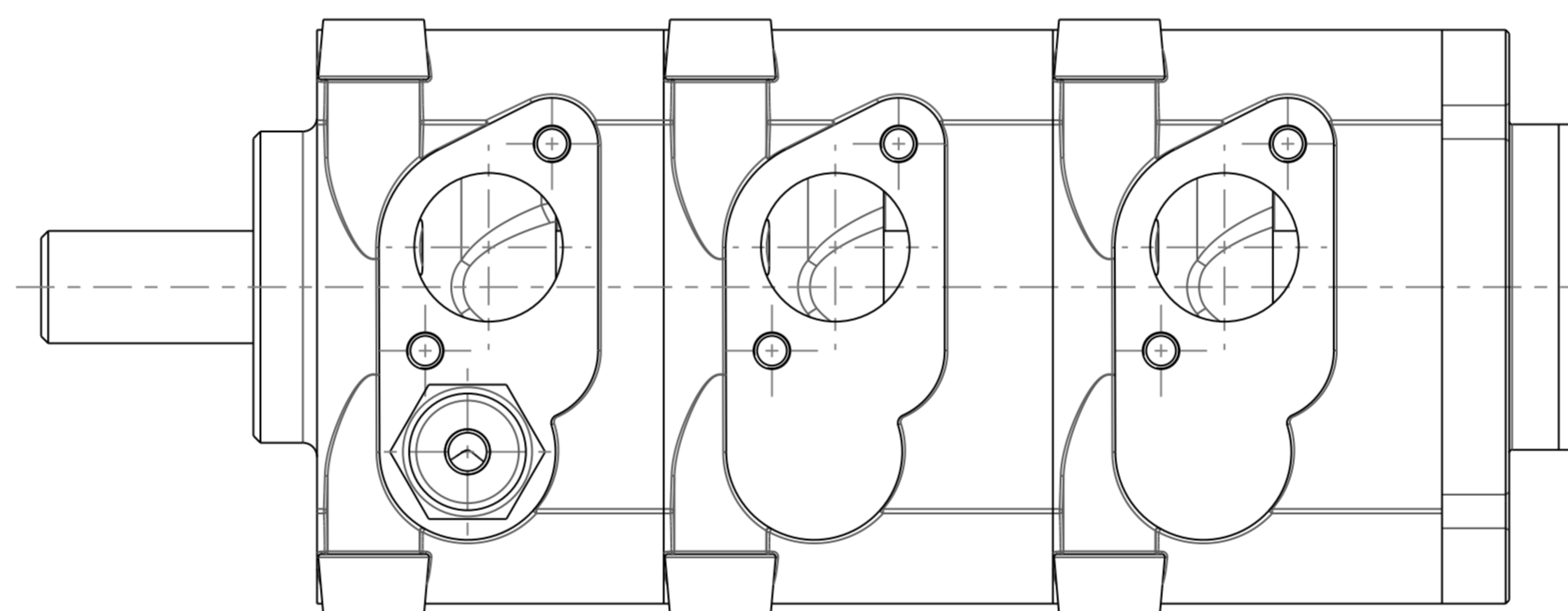

VIEW LOOKING AT INLET FACE

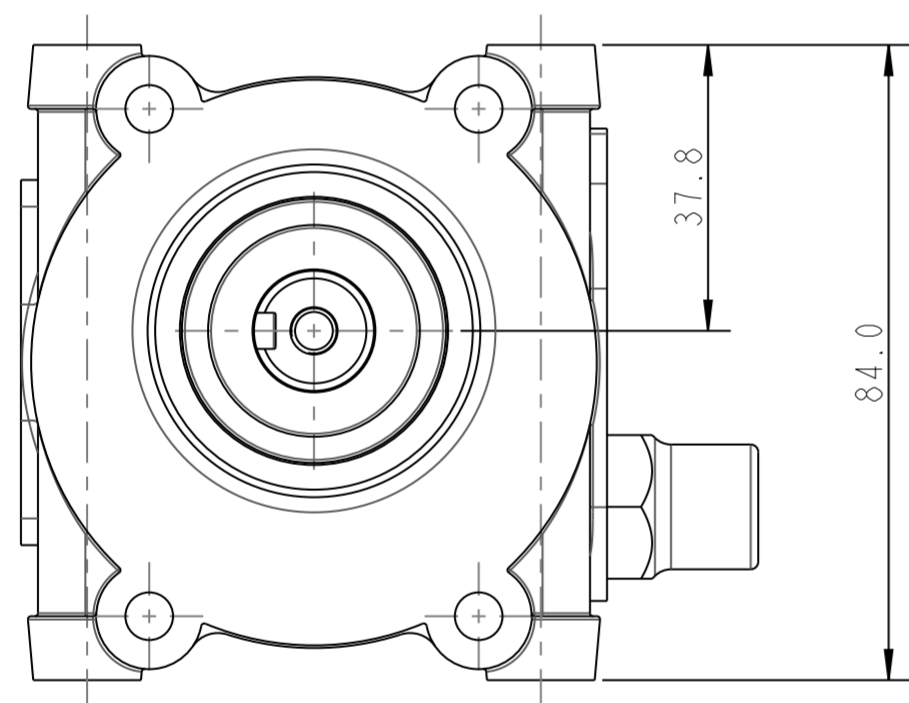
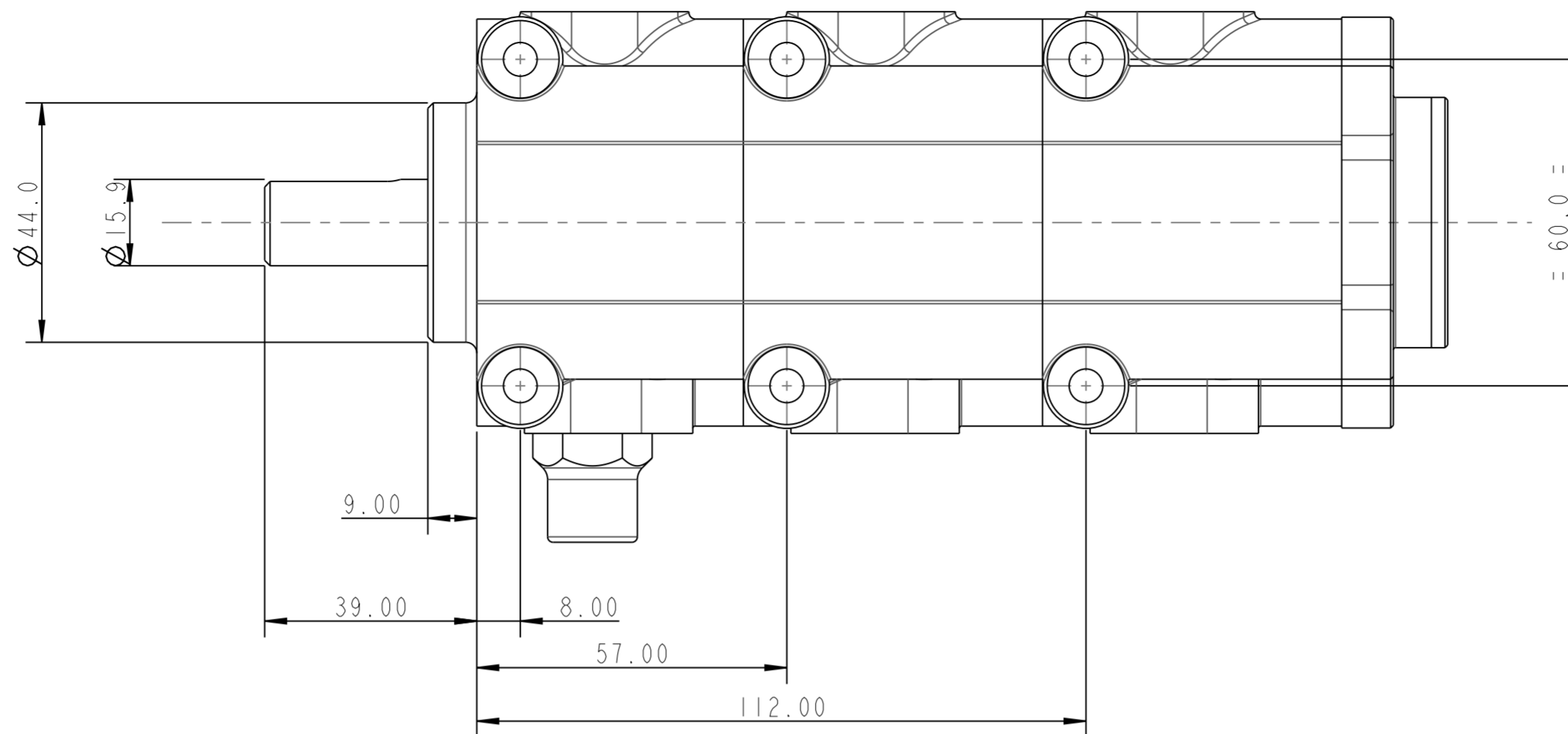
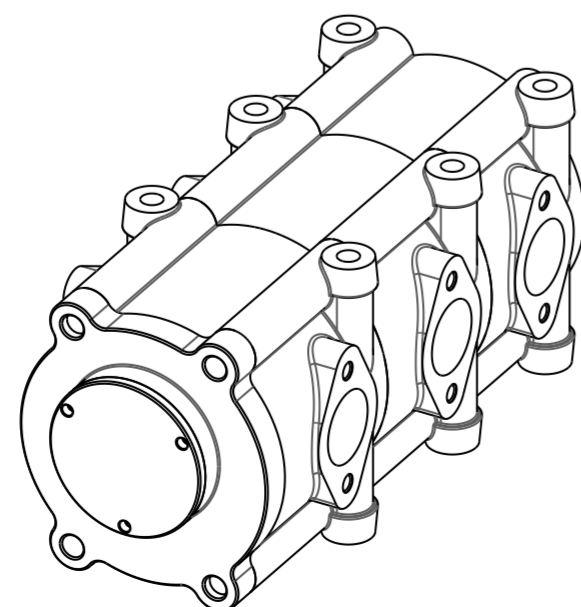
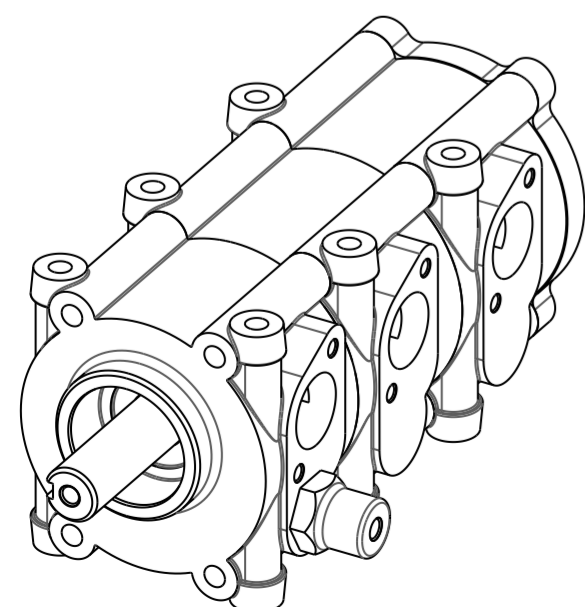

A		INITIAL ISSUE		-	-
ISS	DATE	DETAILS	DRAWN	CHK'D	APP'D
DIMENSIONS IN mm ANGLES IN DEGREES.		GENERAL MACHINED FINISH N7 U.O.S			
TOLERANCES AS BELOW U.O.S.		REMOVE ALL BURRS AND SHARP EDGES			
±0.40	0 DECIMAL PLACES	DO NOT SCALE - IF IN DOUBT ASK	SCALE:	1:1	
±0.20	1 DECIMAL PLACE		QTY.		
±0.10	2 DECIMAL PLACES		WEIGHT:		
±0.02	3 DECIMAL PLACES				
MATERIAL:					
HEAT TREAT:					
FINISH:					

A2	TITLE	DRAWING NO.
	PUMP ASSY - BG 0.6"P & 2x0.941"S, REAR BRG.	00-05-005-0-0-A

This drawing is the property of PACE PRODUCTS LTD. It must not be reproduced or copied and must be returned at any time on demand. This drawing is also confidential and must be disclosed to no other than an employee requiring it for the job. It is a condition under which this job is placed that no goods will be made, modified or repaired from the drawing except in accordance with an official order from PACE PRODUCTS LTD.