

## EWP<sup>®</sup> 110--24v INSTALLATION INSTRUCTIONS

### DAVIES, CRAIG EWP<sup>®</sup> (ELECTRIC WATER PUMP) AND OPTIONS FOR PUMP CONTROL

Congratulations on your purchase of the Davies, Craig EWP<sup>®</sup> which is designed to replace or supplement the existing belt driven mechanical water pump of your engine. It has a high flow capacity and has the advantage of running at a speed independent of the engine speed. It can be controlled by the engine temperature or the need for engine cooling, in much the same way as electric engine cooling fans operate. The EWP<sup>®</sup> can also be set to continue running after engine shut down to prevent damaging heat soak. When your EWP<sup>®</sup> is used to replace the mechanical pump, you will notice an increase in engine power and torque, especially at high engine speeds. Automatic gear changes, both up and down, will be smoother.

**PLEASE READ THESE INSTRUCTIONS IN THEIR ENTIRETY BEFORE YOU START WORK**

#### EWP<sup>®</sup> COMPONENTS:

No.	Description	Qty.
1.	Hose Clamps	2
2.	Straight Adaptor	1
3.	Angled Adaptor	1
4.	O-rings	2
5.	EWP Pump Assy.	1
6.	Hardware Bag	1
7.	Thin Rubber Sleeve	2
8.	Thick Rubber Sleeve	2

#### HARDWARE COMPONENTS:

No.	Description	Qty.
6a.	Wiring Harness	1
6b.	Relay	1
6c.	Scotchlock	1
6d.	Ring Terminal	1
6e.	Blade Fuse	1
6f.	Self Tapper	1
6g.	Short bolts	6
6h.	Long bolts	6
6i.	Nuts	6
6j.	Washers	18

*Please contact Davies, Craig for additional straight or angled adaptors if required.*



### SECTION ONE: INSTALLING THE EWP<sup>®</sup> 110

1. The EWP<sup>®</sup> 110 is better fitted in the lower radiator hose connecting the radiator to the existing mechanical water pump housing. Check the area for available space and shape of the hose. The section of radiator hose connected to the radiator must be connected to the inlet of the electric pump and the section of radiator hose connected to the original pump/engine block must be connected to the outlet of the electric water pump. The pump inlet and outlet are marked on the pump. The EWP<sup>®</sup> should be positioned as low as possible to maximise the gravity feed from the radiator and prevent air entering the pump. Alternatively, it can be fitted in the upper hose, but in this case the coolant level must be maintained and the section of radiator hose connected to the top of the radiator must be connected to the outlet of the electric pump and the section of radiator hose connected to the engine block must be connected to the inlet of the electric water pump. The

---

pump can be installed in any orientation. Assemble the EWP<sup>®</sup> plastic adaptors (Item No's: 2,3) to suit the hose configuration and space available. Make sure that the adaptors have an o-ring (Item No: 4) between them and the flange faces on the pump body. The short bolts (Item No: 6g) supplied should be used to connect the adaptor (Item Nos: 2,3) to the inlet face and the longer bolts (Item No: 6h) to connect the adaptor (Item Nos: 2,3) to the outlet face with the nuts (Item No: 6i) provided. The washers (Item No: 6j) provided should be used between the bolt head and the flange face and between the nut and flange face.

2. Add the appropriate thickness rubber sleeves (Item No's: 7,8) to the adaptors (Item No's: 2,3), if required, to suit your particular hose diameter.
  3. Cut out the required section of the radiator hose. Connect the pump inlet and outlet to the appropriate hoses.
- 

## **SECTION TWO: OPTIONS FOR PUMP CONTROL**

WARNING: Use of the EWP for LPG vehicle is not recommended as LPG converter requires continuous flow through heater circuit to ensure converter does not freeze-up.

### **1. Continuous running with thermostat:**

Wire the pump direct to the ignition for thermostat controlled cooling. With the ignition on, or when combined with a turbo-timer (not supplied), the EWP<sup>®</sup> will run on after a hot engine shut down, eliminating heat soak.

**OR**

### **2. Continuous running without thermostat:**

Wire the pump direct to the ignition for maximum cooling and remove Engine thermostat. With the ignition on, or when combined with a turbo-timer (not supplied), the EWP<sup>®</sup> will run on after a hot engine shut down, eliminating heat soak.

**OR**

### **3. As extra cooling with Davies, Craig Thermal Switch, P/No: 0401:**

Combine the EWP<sup>®</sup> with an on/off thermal switch when the EWP<sup>®</sup> is used as a booster pump to the existing mechanical pump in an overheating cooling system. With the thermal switch connected to the battery, the EWP<sup>®</sup> will run on after a hot engine shut down, eliminating heat soak. Leave the thermostat in place but set the EWP<sup>®</sup> to run at or after the thermostat is open.

### **4. PLEASE NOTE THAT CONTROLLER PART NO. 8010 & 8020 ARE NOT SUITABLE FOR USE WITH 24V PUMPS.**

---

## **OPTION 1 & 2: CONTINUOUS RUNNING WITH/WITHOUT THERMOSTAT.**

This option allows the replacement of the mechanical water pump with the EWP. Remove the thermostat if you wish.

### **MODIFYING EXISTING PUMP**

#### **1. Either:**

- A. Remove the existing belt driven water pump.
- B. Pull the pump impeller off the pump shaft or remove the vanes from impeller in situ. (NOTE: You may need to drill holes through the impeller close to the drive shaft to make it easier to remove.)
- C. Re-fit the water pump housing ensuring that there is no damage to the water pump gasket and the pump seal is still retained. Re-fit the water pump belt and tighten to manufacturer's specifications.

**Or:**

- By-pass the belt drive on the water-pump (if possible) by installing a shorter belt that omits the pump pulley. For example



- Connect the EWP wiring harness and relay. (**Refer wiring diagram 1**)
- Bleed the EWP<sup>®</sup>. Refer to “**BLEEDING THE EWP<sup>®</sup>**” on page 5. After bleeding the EWP<sup>®</sup> continue on with the next stage.

### RUNNING THE EWP<sup>®</sup>

Run the engine and monitor the engine temperature. If the ignition is left on (or if a turbo timer is connected) after a hot shut down, the pump will continue to run and stop engine heat soak. Tighten hose clamps after a few hours running at temperature and again after 20 hours running. Check for leaks. Note, if thermostat is removed the heater circuit may take longer to warm up.

### WIRING DIAGRAM 1: EWP<sup>®</sup> CONTINUOUS RUNNING:

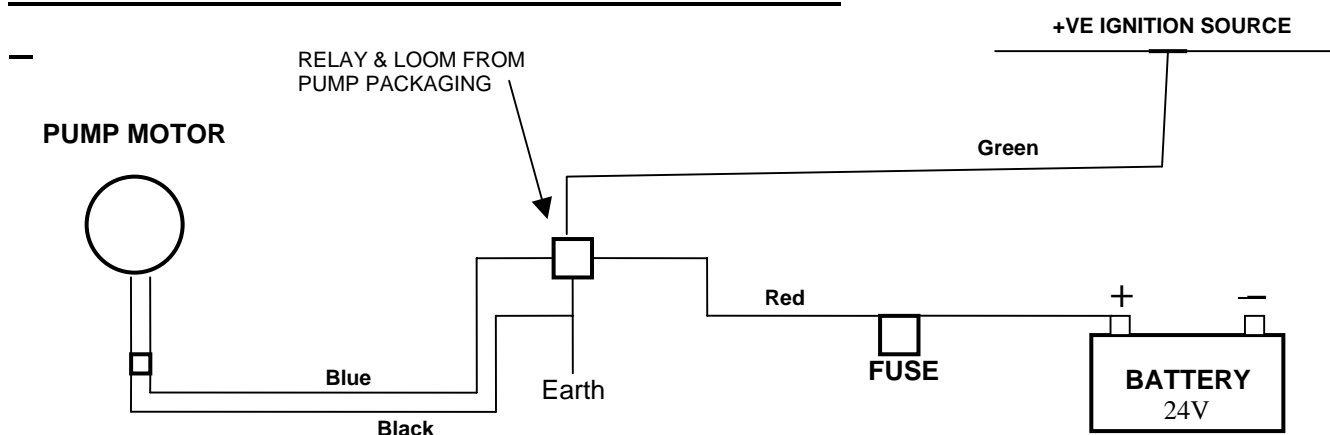

### **OPTION 3: USING THE EWP<sup>®</sup> TO BOOST THE COOLING SYSTEM WHEN REQUIRED WITH AN ON/OFF THERMAL SWITCH.**

This option when combined with a Davies, Craig Thermal Switch, P/No: 0401 will turn the EWP<sup>®</sup> on at the temperature you set, to give an added boost to the cooling system. To simplify installation of thermal switch you may decide to use Temperature Sensor Adaptor Kit, Part No. 0409.

This Kit allows the thermal switch capillary to be installed directly into the radiator hose without the need to insert between the radiator hose and radiator inlet.



## INSTALLING THERMAL SWITCH (Refer wiring diagram 2)

1. When the engine is cold remove the top radiator hose at the radiator end.
2. Mount the thermal switch on the right angle bracket with the two screws provided. Mount the bracket beside the radiator with the two self-tapping screws so that the capillary will reach the top radiator ferrule (pipe) and so that the switch is available for adjustment.

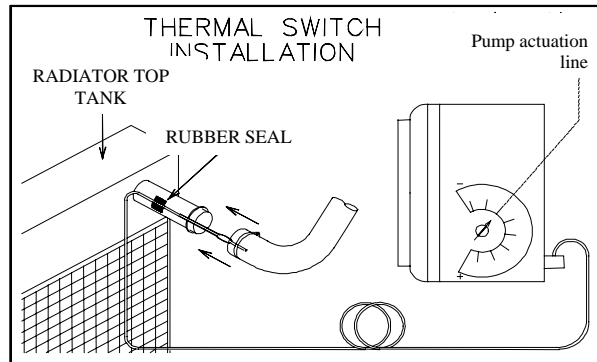

3. Lay the rubber seal along the radiator ferrule and place a section of the capillary of the thermal switch down the groove in the rubber seal. Keep the capillary loosely coiled and prevent sharp bends. Pass the bulb at the end of the capillary down over the radiator inlet ferrule so that it protrudes no more than a few inches into the radiator hose. You may choose to use insulation tape to hold the seal in place while the hose is refitted. Replace radiator hose; position hose clamp across centre of seal with the clamp screw on the opposite side to the capillary. A good silicon type sealant may be used if there is a persistent leak.
4. Connect the pump wiring harness to the pump. Connect the GREEN wire from the relay to the thermal switch. Connect the BLUE wire provided with the thermal switch to battery positive.
5. Bleed the EWP<sup>®</sup>. Refer to “**BLEEDING THE EWP<sup>®</sup>**” on page 5. After bleeding the EWP<sup>®</sup> continue on with the next stage.

## RUNNING THE EWP<sup>®</sup>

Run the engine and monitor the engine temperature, adjusting the thermal switch dial to turn the EWP<sup>®</sup> on, at or above thermostat opening temperature. With the thermal switch connected directly to the battery, after a hot shut down, the pump will continue to run and prevent engine heat soak and turn off. Tighten clamps after a few hours running at temperature and again after 20 hours running. Check for leaks.

## WIRING DIAGRAM 2: EWP<sup>®</sup> WITH THERMAL SWITCH - P/NO: 0401:

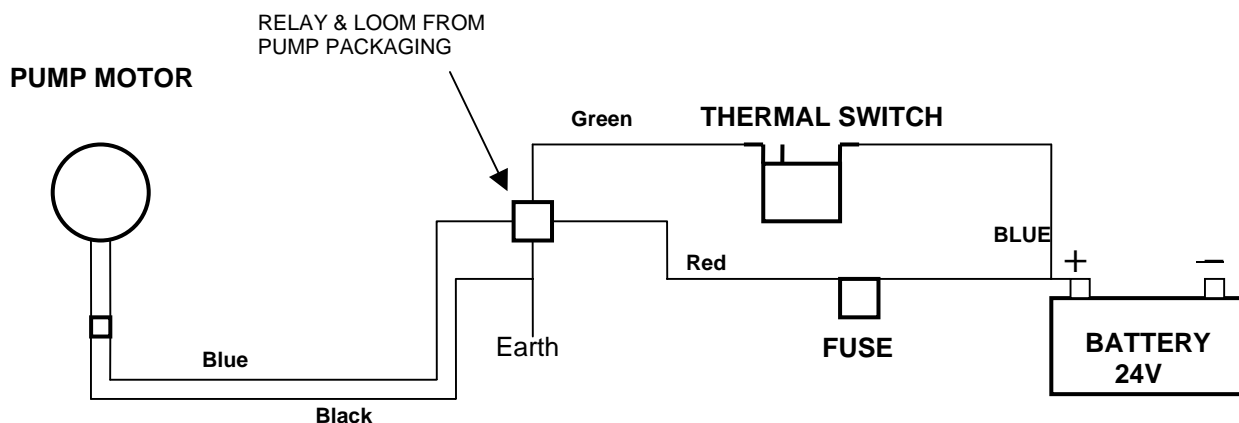

---

## **BLEEDING THE EWP®**

Ensure the EWP® is orientated correctly as shown below before continuing and hose clamps are tight.

NOTE: This orientation is a temporary requirement for the purpose of bleeding the pump and ensuring there is no air entrapped within the seal housing of the pump. The pump can be set-up in another orientation upon completion of the bleeding procedure.

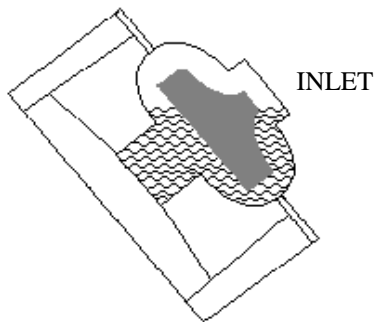

**FIGURE 1: CORRECT ORIENTATION**

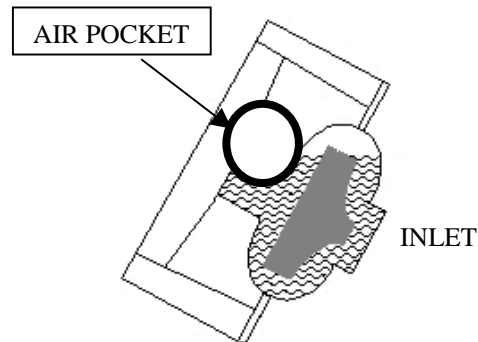

**FIGURE 2: INCORRECT ORIENTATION**

1. Fill up the cooling system with appropriate coolant.
2. Do not run the engine but hardwire the pump direct to the battery so that the pump runs at full power.
3. With the radiator cap off, run the pump for 5 - 10 minutes to ensure that there is no air trapped in the cooling system. Fill with coolant as the air is removed from the system.
4. Once all air is removed from the cooling system replace the radiator cap and reconnect the pump to your original controlling method.

NOTE: The pump orientation can be changed by slightly loosening the hose clamps and rotating pump to desired position. If leakage occurs from hoses during re-positioning, the coolant level must be topped up. Ensure that hose clamps are tight.

**These installation instructions will suit most situations but there are many conditions of engine design, environment, and the kind of motoring involved, which may call for other arrangements not described here. Advice is available from Davies, Craig and we would very much appreciate your feedback.**

---

## **WARNINGS**

- Do not run pump dry as seal damage may occur and your warranty will be void.
- Engine temperature must be monitored closely at all times but especially immediately after installation and until pump operation and capacity have been proved.
- Use of the EWP® after removing the pump impeller or deleting the mechanical pump pulley from the belt system will increase maximum engine speed. Running an engine at higher speeds than normal may affect other engine components.
- The EWP® can handle most rust particles and sludge found in cooling systems but large rust particles should be flushed from the radiator before the EWP® is installed.
- Some vehicles may require special bleeding procedures to remove air from the cooling system not described here. The EWP must be completely flooded with coolant at all times to achieve the life specification of the EWP and to preserve warranty.
- Do not use the vehicle's engine management system or wiring connected to the vehicle's engine management system as an ignition source because it may cause failure of the management system and/or the electrical system. The ignition source must be a steady positive supply of 24-26 VDC.

- 
- Vehicles with both heater circuit inlet (return) and outlet ports in the mechanical pump housing will suffer reduced heater performance unless the heater return position is relocated (suggest top radiator hose).
  - The cooling system must have antifreeze in accordance to the vehicle manufacturer's specification.
  - The EWP is a 'circulation' pump ideal for 'closed circuit' operation similar to an automotive cooling system. It is not a 'self-priming' pump and therefore will not operate efficiently without a positive 'head' in an 'open' system
  - The impeller tip clearance is very tight for maximum efficiency, and may when new actually scrape the pump housing causing a slight noise. The impeller will bed in over time and the noise cease.

### **EWP<sup>®</sup> Installation Recommendations**

To ensure maximum life and optimum performance from your new EWP<sup>®</sup>, Davies, Craig recommends:

- If an EWP<sup>®</sup> is installed on a vehicle which is kept in storage for more than 3 months, (e.g. a show or race-car), it is advised that the pump be operated for approximately 5mins constant running every month. This will minimise the build up of any sediment in the EWP<sup>®</sup> and also lubricate all parts within the pump.
- It is recommended that the cooling system is flushed every 6 months or 10,000kms to remove any built up sediment in the cooling system.
- If you fabricate metal hose adapters to replace the plastic ones supplied, be sure the bolt holes match those on the pump body precisely, because tightening bolts through misaligned holes may tend to pull the two halves of the pump body apart.